

DAYTONA

ANIMA F, FDX, FLX ENGINE

Owner's Manual

ENGINE No. ANIMA190FDX/FLX: 2745000000-
ENGINE No. ANIMA150FDX/FLX: 2745000000-
ENGINE No. ANIMA190/150F : 2745000000-

ENGLISH MANUAL SECTION

Page 1 - 21

PARTS CATALOGUE SECTION

Page 21 - 32



DAYTONA corp.



INTRODUCTION

Thank you for purchasing of a ANIMA Engine.

This manual explains operation, inspection, basic maintenance and tuning of the engine.

If you have any questions, please contact the dealer you purchased the engine/bike from.

Please read this manual very carefully before use.



WARNING

1. ANIMA ENGINE is designed strictly FOR COMPETITION USE, ONLY ON A CLOSED COURSE. It is illegal to use this engine on any public road or highway. Off-road use on public space is also illegal.
Please check local regulation before use.
2. This engine is to be used by EXPERIENCED RIDERS ONLY.
Fatal accident may be caused unless it is used by experienced riders or maintained by professional and experienced mechanics.
3. This engine is to be maintained by professional and experienced mechanics.
Serious damage may occur, otherwise.
4. This manual explains ONLY THE BASIC operation, inspection, maintenance and tuning, but it is customer's responsibility to maintain the engine to the best possible performance, depending on the circumstances of the time.

CUSTOMER'S RESPONSIBILITY & CUSTOMER SERVICE

GENERAL EXCLUSIONS

Any failures caused by the following reasons are NOT considered as the defects of Products.

- (1) Overheating due to improper engine oil temp. control



WARNING

ENGINE OIL TEMPERATURE MUST BE CONTROLLED AT 90 DEGREES CELSIUS (194 DEGREES FAHRENHEIT) OR LOWER.

Serious damage will occur in the engine if engine oil temperature exceeds 90 degrees Celsius or 194 degrees Fahrenheit.

It is solely customer's responsibility to control the engine oil temperature.

- (2) Installation of parts or accessories that is not originally equipped on Products.
This includes DAYTONA UPGRADE KIT PARTS as well, since those are designed for the top competition riders.
- (3) Abnormal strain, neglect, or abuse
- (4) Accident or collision damage
- (5) Modification to original parts
- (6) Lack of proper maintenance
- (7) Damage due to improper transportation or use

THE CUSTOMER'S RESPONSIBILITY

THE CUSTOMER'S RESPONSIBILITY shall be :

- (1) Operate and maintain Products as specified in the appropriate Owner's Manual
- (2) Prohibit the modification of the product

CUSTOMER SERVICE

If Products require services, you must take it to the authorized dealer, who is appointed by authorized local distributors of DAYTONA.

DAYTONA Corp. JAPAN is NOT in the position to take care of services of any kind with the customers or authorized dealers due to the contract with authorized local distributors.

CONTENTS

INTRODUCTION	Page 1
CUSTOMER'S RESPONSIBILITY & CUSTOMER SERVICE	Page 2
CONTENTS	Page 3
PART NAMES	Page 4
GENERAL SPECIFICATIONS	Page 5
MAINTENANCE SPECIFICATIONS	Page 6 – 9
MAINTENANCE INTERVALS	Page 10 - 12
PRE-OPERATION INSPECTION AND MAINTENANCE	Page 13 - 19
ENGINE OIL LEVEL INSPECTION	Page 13
CARBURETOR SETTING	Page 14 - 16
IGNITION TIMING SELECTION	Page 17
REV LIMITER SELECTION	Page 18
ENGINE OIL TEMPERATURE CONTROL	Page 19
ELECTRICAL DIAGRAM	Page 20 - 21
PARTS CATALOGUE	Page 22 – 32

PART NAMES

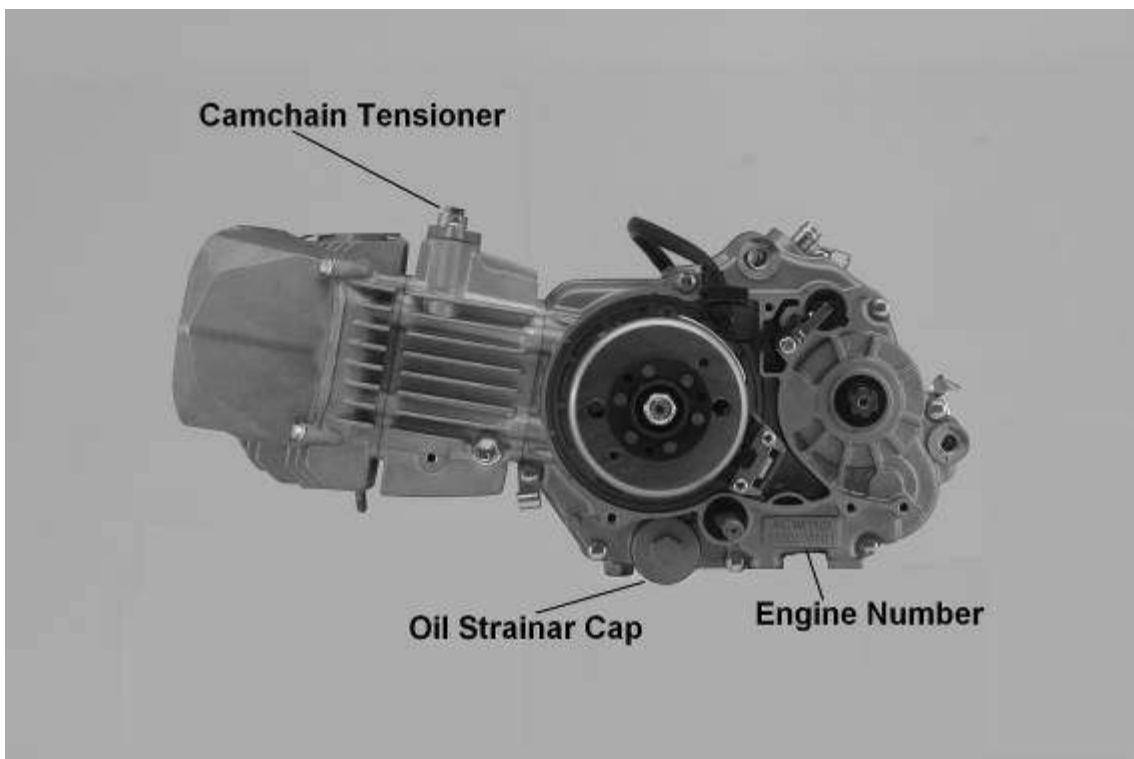
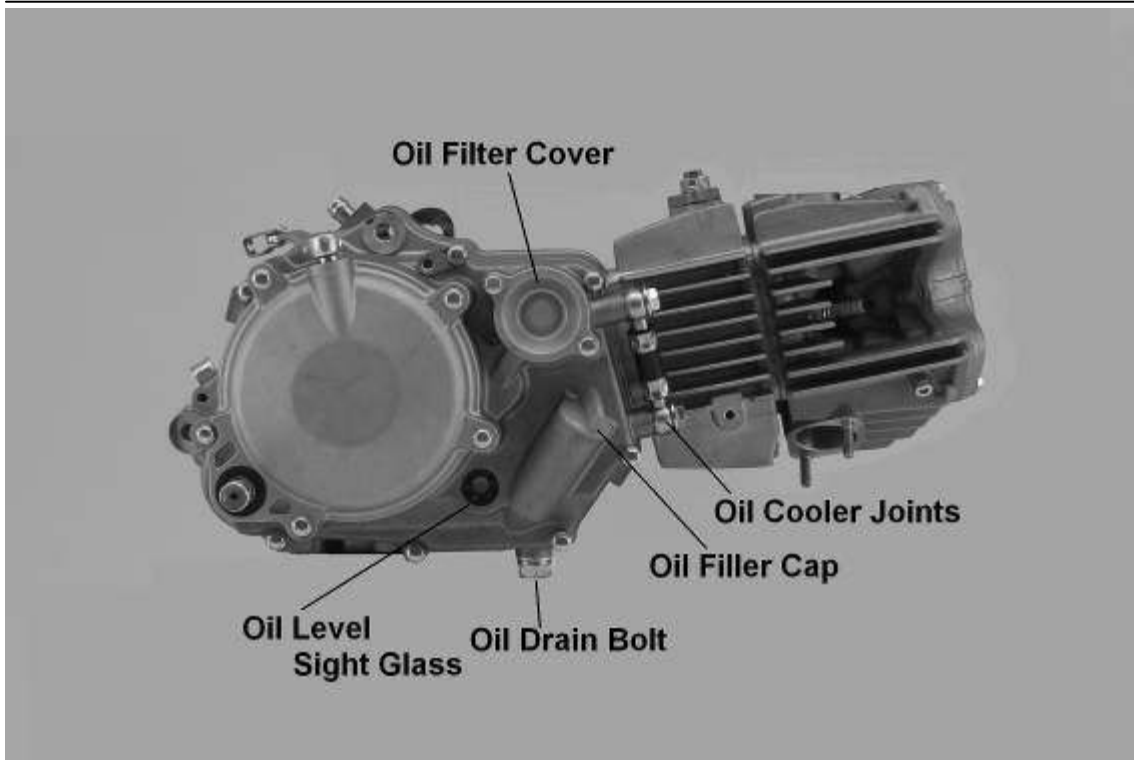

GENERAL SPECIFICATIONS

ENGINE		
Engine Weight (Dry)	21.5 kg	
Engine type	Air Cooled 4-stroke SOHC	
Cylinder arrangement	Single cylinder, Horizontally mounted	
Displacement	187.18 cm ³ (ANIMA190), 149.74cm ³ (ANIMA150)	
Bore × stroke	62.0× 62.0mm(ANIMA190), 62.0 x 49.6mm(ANIMA150)	
Compression ratio	12.1 : 1	
Starting system	Kick (Kick pedal is NOT included in the Engine Kit) With Decompression System	
Lubrication system	Wet sump	
Recommended Engine Oil	SAE 10W - 40 or higher grade API "SG" or higher grade	
Engine oil capacity		
Periodic oil change	0.60 L	
With oil filter replacement	0.65 L	
Total amount	0.70 L	
	* Need more amount of oil when oil cooler is in use	
Spark plug		
Type/manufacturer	ER9EH / NGK (resistance type)	
Gap	0.6 ~ 0.7 mm (0.024 ~ 0.028 in)	
Clutch type	Wet, Multi-plate 6-disc	
Transmission	FDX, FLX model	F model
Primary reduction system	Gear	
Primary reduction ratio	67/18 (3.722)	←
Transmission type	4-Speed	←
Gear ratio	(Counter / Main)	
1st	34/13 (2.6153)	←
2nd	26/15 (1.7333)	←
3rd	26/20 (1.3000)	25/21 (1.1094)
4th	24/23 (1.0435)	22/24 (0.9166)
GEAR SHIFT PATTERN	N-1-2-3-4	1-N-2-3-4
Electrical		
Ignition system	AC-CDI	
Generator system	AC magneto	

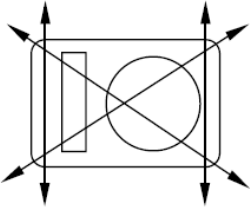
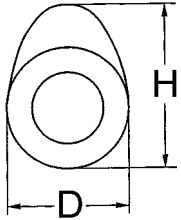

MAINTENANCE SPECIFICATIONS

Item	Standard	Limit
Cylinder head Warp limit 	----	0.05 mm (0.002 in)
Cylinder: Bore size Out of round limit	62.00 - 62.015mm (2.4409 – 2.4415) ----	---- 0.05 mm (0.002 in)
Camshaft: Drive method Cam dimensions 	Chain drive (Left)	----
Intake	“H” 30.18 ~ 30.30 mm (1.1882 ~ 1.1929 in) “D” ---- ----	29.84 mm (1.1748 in) ---- ----
Exhaust	“H” 30.21 ~ 30.33 mm (1.1894 ~ 1.1941 in) “D” ---- ----	29.87 mm (1.1760 in) ---- ----

MAINTENANCE SPECIFICATIONS

Item	Standard	Limit
Timing chain: Timing chain No. of links Timing chain adjustment method	94 link Automatic	---- ----
Valve, valve seat, valve guide: Valve clearance (cold) IN EX	0.05 ~ 0.07 mm (0.0020~ 0.0028 in) 0.05 ~ 0.07 mm (0.0020~ 0.0028 in)	---- ----
Valve dimensions:		
“A” head diameter IN EX	24.4 ~ 24.6 mm (0.9606 ~ 0.9685 in) 20.9 ~ 21.1 mm (0.8228 ~ 0.8307 in)	---- ----
“B” face width IN EX	--- ---	---- ----
“C” seat width IN EX	0.8 ~ 1.0 mm (0.0314 ~ 0.03937 in) 0.8 ~ 1.0 mm (0.0314 ~ 0.03937 in)	1.6 mm (0.0630 in) 1.6 mm (0.0630 in)
“D” margin thickness IN EX	---- ----	---- ----
Stem outside diameter IN EX	4.470 ~ 4.485 mm(0.17598 ~ 0.1766 in) 4.470 ~ 4.485 mm(0.17598 ~ 0.1766 in)	4.42 mm (0.1740 in) 4.42 mm (0.1740 in)
Guide inside diameter IN EX	4.500 ~ 4.512 mm(0.17716 ~ 0.1776 in) 4.500 ~ 4.512 mm(0.17716 ~ 0.1776 in)	4.55 mm(0.1791 in) 4.55 mm(0.1791 in)
Stem-to-guide clearance IN EX	0.015 ~ 0.042 mm(0.0005 ~ 0.0016 in) 0.03 ~ 0.057 mm(0.0011 ~ 0.0022 in)	0.08 mm(0.003 in) 0.10 mm(0.004 in)
Valve spring: Free length IN (φ 16.2) EX (φ 16.2)	42.59 mm(1.6767 in) 42.59 mm(1.6767 in)	40.38 mm(1.5897 in) 40.38 mm(1.5897 in)

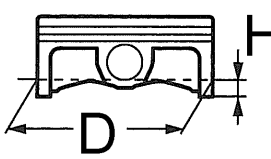
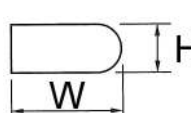
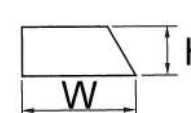
MAINTENANCE SPECIFICATIONS

Item	Standard	Limit
<p>Piston:</p> <p>Piston to cylinder clearance</p> <p style="text-align: center;">Piston size "D"</p>  <p style="text-align: center;">Measuring point "H"</p> <p style="text-align: center;">Piston off-set</p> <p style="text-align: center;">Piston pin bore inside diameter</p> <p style="text-align: center;">Piston pin outside diameter</p>	<p>0.01 ~ 0.04 mm (0.00039 ~ 0.00157in)</p> <p>61.975 ~ 61.99 mm (2.4399 ~ 2.4405 in)</p> <p>8 mm (0.31 in)</p> <p>----</p> <p>14.002 ~ 14.013 mm (0.5513 ~ 0.5517 in)</p> <p>13.995 ~ 13.998 mm (0.5510 ~ 0.5511 in)</p>	<p>0.1mm(0.004 in)</p> <p>----</p> <p>14.06 mm (0.5535 in)</p> <p>13.97 mm (0.55 in)</p>
<p>Piston rings:</p>  <p>Top ring:</p> <p>Dimensions (H × W)</p> <p>End gap (installed)</p> <p>Side clearance (installed)</p>  <p>2nd ring:</p> <p>Dimensions (H × W)</p> <p>End gap (installed)</p> <p>Side clearance</p>  <p>Oil ring:</p> <p>Dimensions (H × W)</p> <p>End gap (installed)</p>	<p>0.8 × 2.25 mm (0.06 × 0.09 in)</p> <p>0.05 ~ 0.20 mm (0.006 ~ 0.010 in)</p> <p>0.015 ~ 0.045 mm(0.0012 ~ 0.0026in)</p> <p>0.8 × 2.25 mm (0.06 × 0.09 in)</p> <p>0.05 ~ 0.20 mm (0.006 ~ 0.010 in)</p> <p>0.015 ~ 0.045 mm(0.0012 ~ 0.0026in)</p> <p>1.50 × 2.25 mm (0.06 × 0.09 in)</p> <p>0.2 ~ 0.7 mm (0.004 ~ 0.016 in)</p>	<p>0.4 mm (0.020 in)</p> <p>0.10 mm (0.005 in)</p> <p>0.4 mm (0.031 in)</p> <p>0.10 mm (0.005 in)</p> <p>----</p> <p>0.9 mm (0.005 in)</p>

MAINTENANCE SPECIFICATIONS

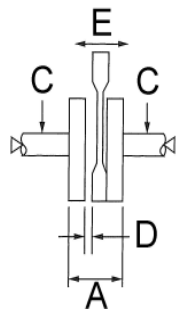
Item	Standard	Limit
Crankshaft: Crank width "A" Runout limit "C" Big end side clearance "D" Small end free play "E" 	42.2 mm (1.66142 in) 0.03 (one-side) 0.1 ~ 0.35 mm (0.0039 ~ 0.0137 in) ----	---- 0.1 mm (0.0039 in) 0.6 mm (0.0236 in)
Clutch: Friction plate thickness Quantity Clutch plate thickness Quantity Warp limit Clutch spring free length Quantity	2.9 ~ 3.1 mm (0.114 ~ 0.122 in) 6 0.9 ~ 1.0 mm (0.043 ~ 0.051 in) 5 ---- ---- 4	2.7 mm (0.106 in) ---- 0.7 mm (0.0275 in) ---- 0.2 mm (0.0787 in) ---- ----

MAINTENANCE INTERVALS

Item	After break-in (50km)	Every race	Every third (or 500 km)	Every fifth (or 1,000 km)	As required	Remarks
ENGINE OIL Replace Inspect	●	●			●	
ENGINE VALVES Check the valve clearances Inspect Replace	●		● ●		●	The engine must be cold. Check the valve seats and valve stems for wear.
VALVE SPRINGS Inspect Replace			●		●	Check the free length and the tilt.
CAMSHAFTS Inspect Replace			●		●	Inspect the camshaft surface.
TIMING CHAIN SPROCKETS, TIMING CHAIN Inspect Replace			●		●	Check for wear on the teeth and for damage.
PISTON Inspect Clean Replace			●		● ● ●	Inspect crack Inspect carbon deposits and eliminate them.

MAINTENANCE INTERVALS

Item	After break- in (50km)	Every race	Every third (or 500 km)	Every fifth (or 1,000 km)	As requir e-ed	Remarks
PISTON RING Inspect Replace			● ●		●	Check ring end gap
PISTON PIN Inspect Replace			●		●	
CYLINDER HEAD Inspect and clean Replace			●		●	Inspect carbon deposits and eliminate them. Change gasket
CYLINDER Inspect and clean Replace			●		●	Inspect score marks Inspect wear
CLUTCH Inspect and adjust Replace	●	●			●	Inspect housing, friction plate, clutch plate and spring
TRANSMISSION Inspect Replace				●	●	Inspect wear of gear and bearings
SHIFT FORK, SHIFT CAM, GUIDE BAR Inspect Replace				●	●	Inspect wear
ROTOR NUT Retighten	●			●		
CRANK Inspect and align				●	●	
CARBURETOR Inspect, adjust, clean	●	●				

MAINTENANCE INTERVALS

Item	After break- in (50km)	Every race	Every third (or 500 km)	Every fifth (or 1,000 km)	As requir e-ed	Remarks
SPARK PLUG Inspect and clean Replace	●		●		●	
OIL COOLING SYSTEM(Optional) Check hoses & leakage Replace hoses and gaskets	●	●			●	
AIR FILTER (Optional) Clean and lubricate Replace	●	●			●	Use foam air-filter oil or equivalent oil
OIL FILTER Replace	●	●				
OIL STRAINER Clean				●		

PRE-OPERATION INSPECTION AND MAINTENANCE

Before riding for break-in operation, practice or a race, make sure the engine is in good operating condition.

Before using this engine, check the following points.

ENGINE OIL LEVEL INSPECTION

1. Start the engine, warm it up for several minutes, and then turn off the engine and wait for a few minutes.
2. Place the bike on a level place and hold it up on upright position.
3. Check the oil level through the sight glass.

Oil level should be between the upper and the central point of the sight glass.

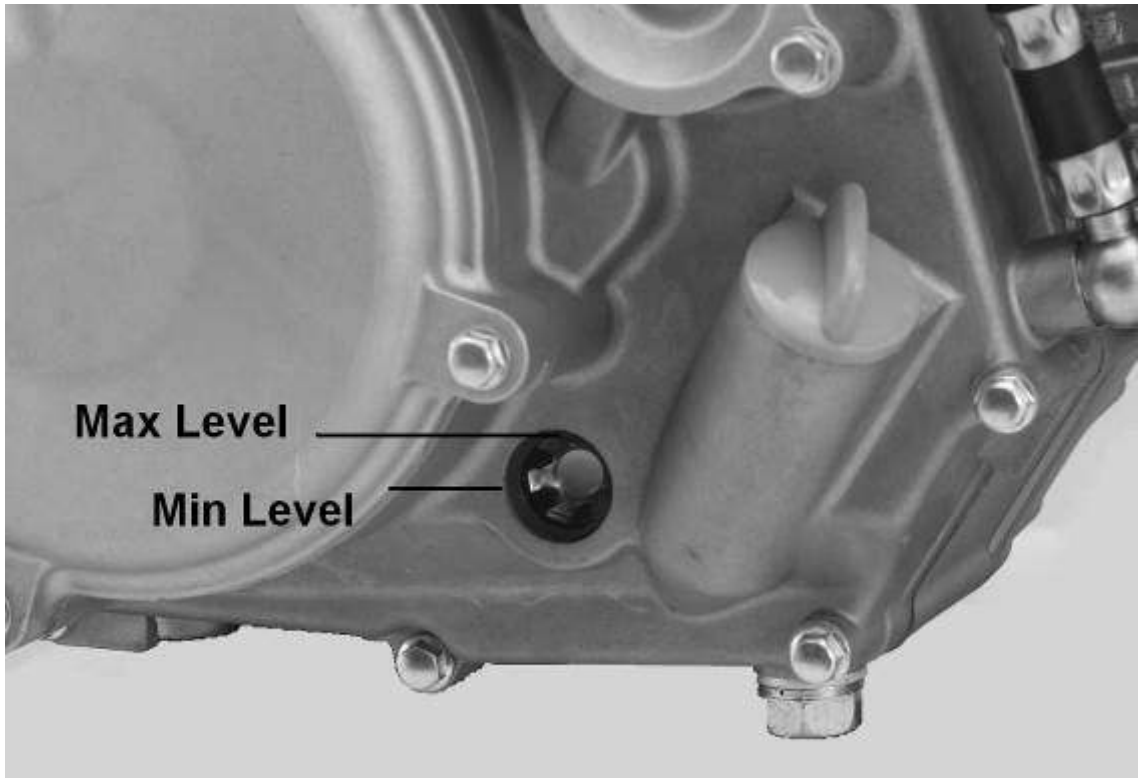

4. Add oil to proper level



WARNING

Add oil as necessary, when install the oil cooler.

PRE-OPERATION INSPECTION AND MAINTENANCE

CARBURETOR SETTING

The carburetor is extremely sensitive to foreign matter (dirt, sand, water, etc.).

During installation, do not allow foreign matter to get into the carburetor.

Always handle the carburetor and its components carefully. Even slight scratches, bends or damage to carburetor parts may prevent the carburetor from functioning correctly.

Carefully perform all servicing with the appropriate tools and without applying excessive force.

After installing the carburetor, check that the throttle operates correctly and opens and closes smoothly.

It is highly recommended that the carburetor setting is performed by an experienced mechanic to obtain the best possible performance.

Atmospheric conditions and carburetor settings

Air Temp.	Humidity	Air Pressure (Altitude)	Mixture	Setting
High	High	Low (High)	Richer	Leaner
Low	Low	High (Low)	Leaner	Richer

The air density (i.e., concentration of oxygen in the air) determines the richness or leanness of the air/fuel mixture. Therefore, refer to the above table for mixture settings.

That is:

- Higher temperature expands the air with its resultant reduced density.
- Higher humidity reduces the amount of oxygen in the air by so much of the water vapor in the same air.
- Lower atmospheric pressure (at a high altitude) reduces the density of the air.

PRE-OPERATION INSPECTION AND MAINTENANCE

Effects of the setting parts on the throttle valve opening

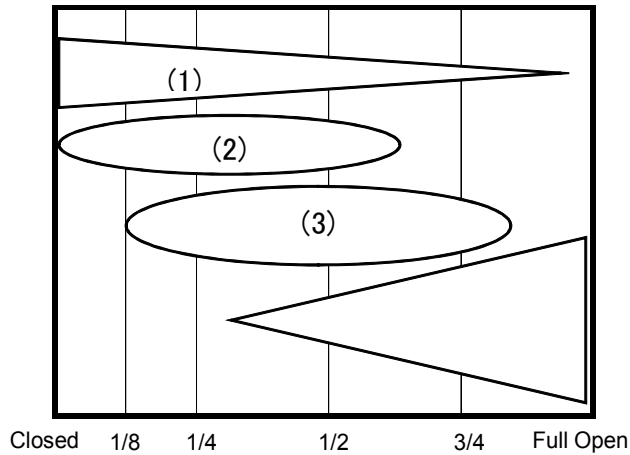

- (1) Slow Jet / Pilot Screw
- (2) Throttle valve cutaway
- (3) Jet Needle / Needle Jet
- (4) Main Jet

Here is the recommended setting information of KEIHIN PWK33 and PE28 carburetor, for your reference.

Tested Conditions

Carburetor	KEIHIN PWK33 (DT#86588)
Air Temperature	20 degrees Celsius
Humidity	50%
Atmospheric Pressure	1000 hPa
Without Air Filter	
Fuel	Octane#100

Item	Recommendation
Main Jet	ANIMA190: #87005 (#125) ANIMA150: #87003 (#120) #87004 (#122) #87005 (#125)
Slow Jet	#87006 (#42)
Throttle Valve	#6.0 (Original of #86588)
Jet Needle	#86590 W956R-1175W(DAYTONA original) #86640 W956R-1171N Clip position : In the 2 nd or 3rd groove from the top
Air screw	2 return

PRE-OPERATION INSPECTION AND MAINTENANCE

Carburetor	KEIHIN PE28 (DT#85707)
Air Temperature	20 degrees Celsius
Humidity	50%
Atmospheric Pressure	1000 hPa
with UNI Air Filter (#UP-4229ST)	
Fuel	Octane#100

Item	Recommendation	
Main Jet	ANIMA190: #87005 (#125)	ANIMA150: #87003 (#120) #87004 (#122) #87005 (#125)
Slow Jet	#87006 (#42)	
Throttle Valve	ANIMA190: #3.0 (Original of #85707)	ANIMA150: #69353 (#2.5)
Jet Needle	#65414 / 46JFQ (-2 / ϕ 2.505) Clip position : In the 3rd groove from the top	
Air screw	2 return	













PRE-OPERATION INSPECTION AND MAINTENANCE

IGNITION TIMING SELECTION: FDX, FLX

ANIMA FDX/FLX ENGINE comes with ignition timing selectable CDI unit.

To change the ignition timing, it needs to change the connection of the wires that come out of the CDI unit.

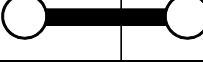
WIRE CONNECTION TABLE

Color of Wire	WHITE	GREEN	YELLOW	GREEN	INGITION TIMING
Timing (1)					 REDUSE
Timing (2)					
Timing (3)					
Timing (4)					
 WARNING USE ADVANCE TIMING GIVES HIGH TEMPERATURE TO ENGINE. SERIOUS DAMAGE WILL OCCURE IN THE ENGINE BY ABNORMAL COMBUSTION.					

Notes

- (a) Reduce Timing gives more torque at low-middle rpm level.
- (b) Advance Timing gives more torque at higher rpm level than the Reduce Timing.

Example (How to select)

* To select Timing (2), connect Yellow and Green wires.

PRE-OPERATION INSPECTION AND MAINTENANCE

REV LIMITER SELECTION: FDX, FLX

ANIMA FDX/FLX ENGINE comes with rev limiter selectable CDI unit.

To change the rev limiter, it needs to change the connection of the wires that come out of the CDI unit.

WIRE CONNECTION TABLE

Color of Wire	BLUE	GREEN	BLACK/ YELLOW
Rev Limiter (1) -11,500rpm	○	○	○
Rev Limiter (2) -12,200rpm	○	○—	○
Rev Limiter (3) -12,900rpm	○—	○	○

Example (How to select)

* To select Rev Limiter (3)-12,900rpm, connect Blue and Green wires.

PRE-OPERATION INSPECTION AND MAINTENANCE

ENGINE OIL TEMPERATURE CONTROL



WARNING

Engine oil temperature is to be strictly controlled at 90 degrees Celsius (194 degrees Fahrenheit) or lower.

Serious damage will occur in the engine if engine oil temperature exceeds 90 degrees Celsius or 194 degrees Fahrenheit.

It is solely customer's responsibility to control the engine oil temperature.

Any failures caused by overheating are NOT considered as the defects of Products.

It is highly recommended to use HIGH-EFFICIENT OIL COOLER and OIL TEMPERATURE GAUGE to protect the engine.



The above OIL COOLER is just a recommendation.

Engine oil temperature can be heated up over 90 degrees Celsius or 194 degrees Fahrenheit, even if the above recommended OIL COOLER is used.

Again, customer needs to control the oil temperature very carefully.

ELECTRICAL DIAGRAM for FDX

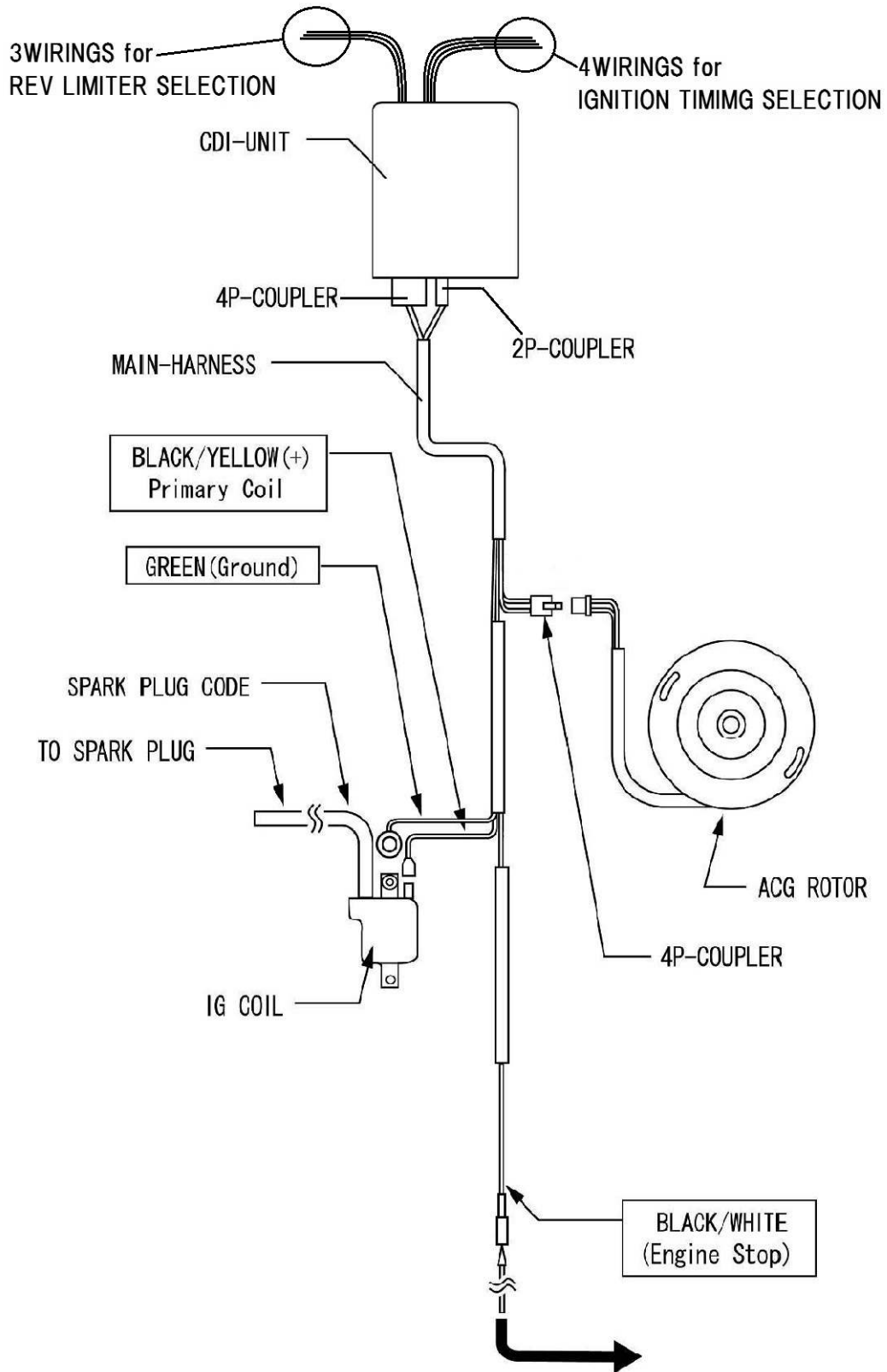

ELECTRICAL DIAGRAM for FLX, F

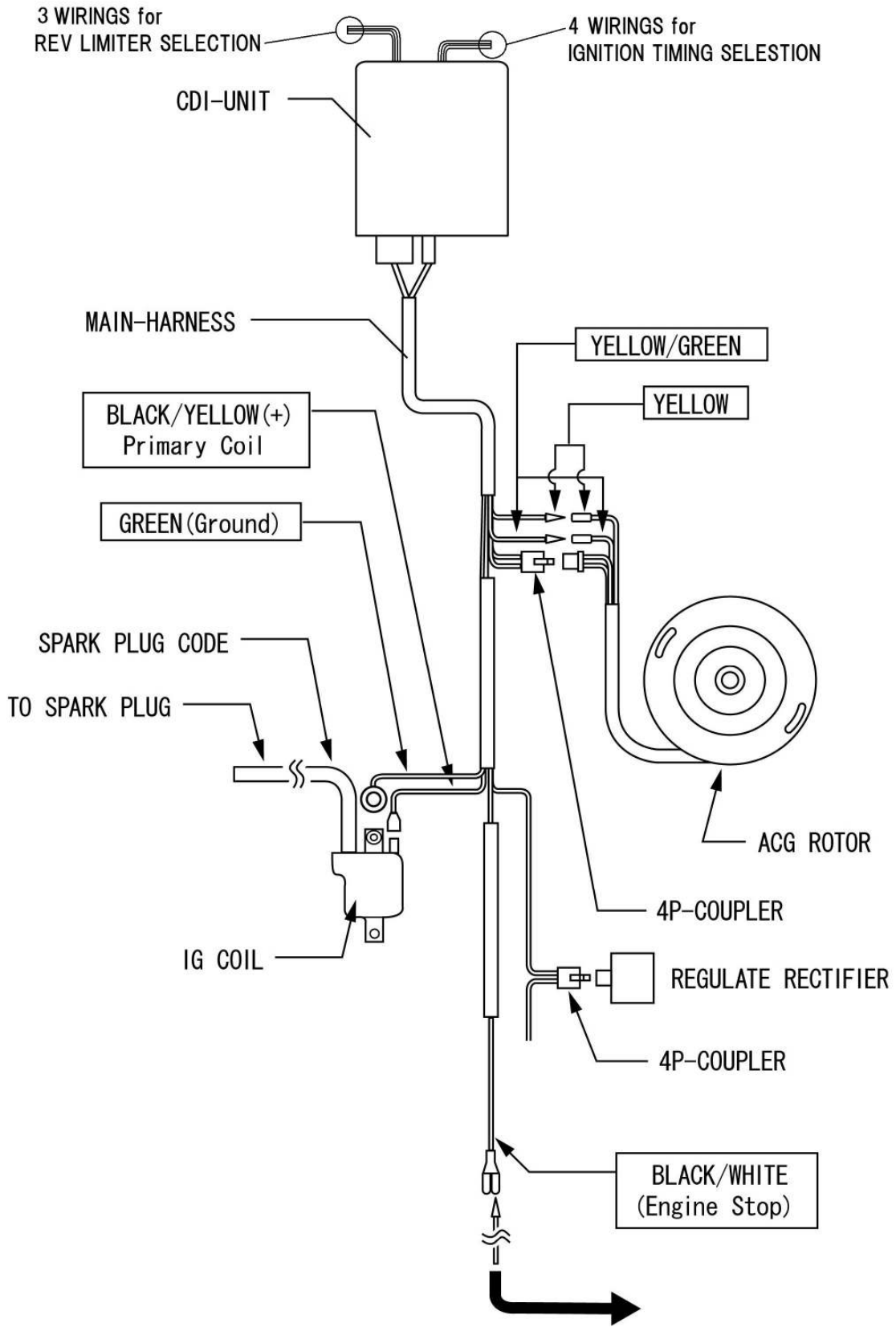

ANIMA "F" model is non-selectable CDI.

PARTS CATALOGUE

Engine No. ANIMA 190/150 FDX/FLX: 2745000000-
 Engine No. ANIMA 190/150 F : 2745000000-



REVISED DATE 19 January, 2012

01 HEAD / CYLINDER

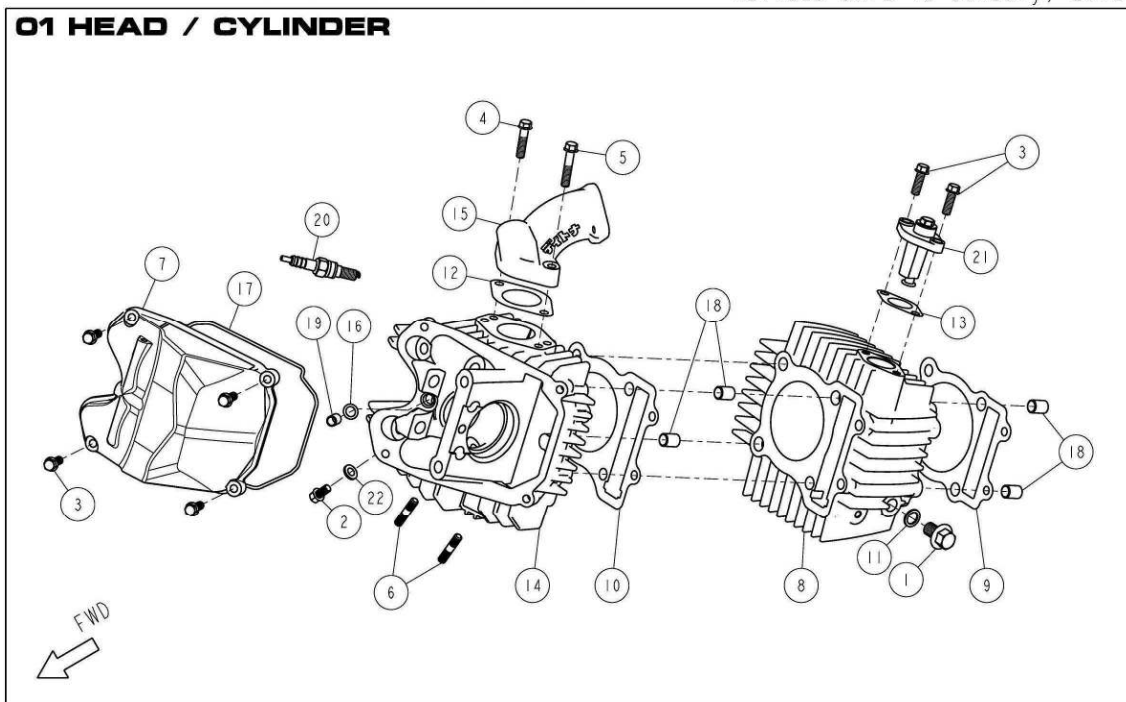

Ref No.	Part No.	DESCRIPTION	QTY	REMARKS
1	86448	BOLT, HEXAGON FLANGE M10x16	1	20N·m
2	85877	BOLT, HEXAGON FLANGE M6x12	1	
3	86468	BOLT, HEXAGON FLANGE M6x18	6	
4	86466	BOLT, HEXAGON FLANGE M6x25	1	
5	86471	BOLT, HEXAGON FLANGE M6x30	1	
6	83703	BOLT, STUD M6x32	2	
7	86367	COVER, CYLINDER HEAD	1	
8	86366	CYLINDER	1	Φ 62.0mm
9	86436	GASKET, BASE CYLINDER	1	t=0.25
10	86440	GASKET, HEAD CYLINDER	1	t=0.25
11	86476	GASKET, M10	1	
12	86405	GASKET, MANIFOLD	1	
13	86439	GASKET, TENSIONER CAM CHAIN	1	
14	86368	HEAD, CYLINDER	1	
15	86404	MANIFOLD, INTAKE	1	
16	86479	O-RING	1	
17	86434	O-RING, COVER HEAD	1	
18	83720	PIN, DOWEL Φ 10xΦ 8.4x14	4	
19	83747	PIN, DOWEL Φ 8xΦ 6.3x12	1	
20	87008	SPARK PLUG ER9EH	1	8N·m
21	86396	TENSIONER, CAM CHAIN COMP	1	
22	86456	WASHER, Φ 6.3xΦ 12x1.5	1	

PARTS CATALOGUE

Engine No. ANIMA 190/150 FDX/FLX: 2745000000-
 Engine No. ANIMA 190/150 F : 2745000000-



O2 VALVE MECHANISM

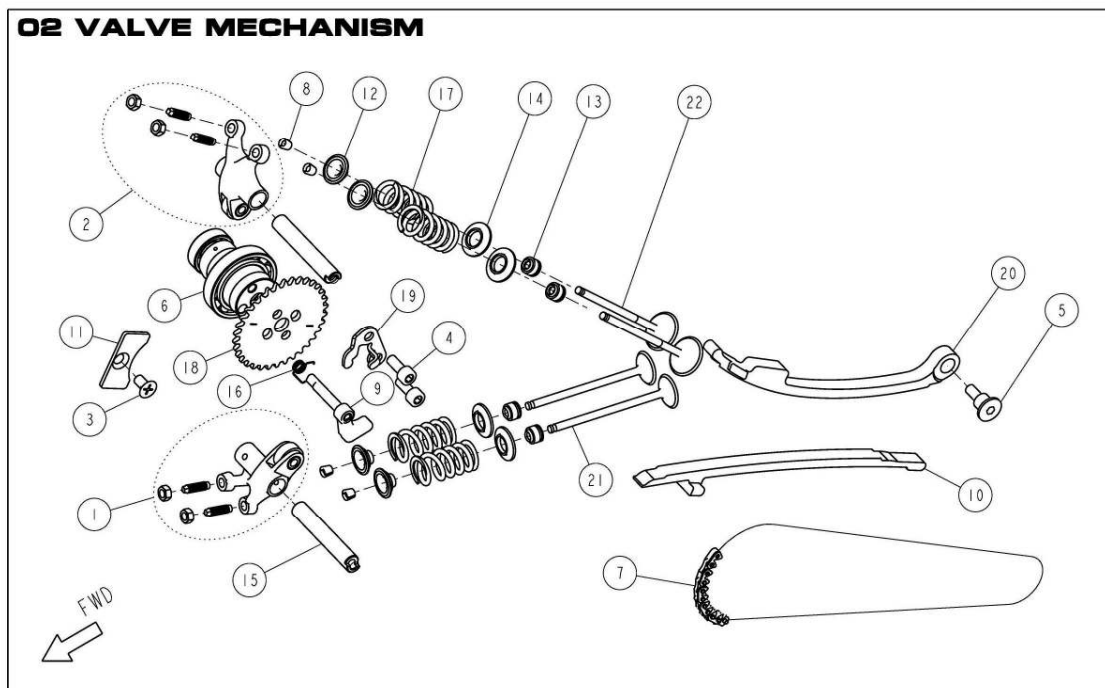

Ref No.	Part No.	DESCRIPTION	QTY	REMARKS
1	86481	ARM, ROCKER ROLLER EX. COMP	1	
2	86393	ARM, ROCKER ROLLER IN. COMP	1	
3	86460	BOLT, COUNTERSINK M6x15	1	10N·m W/THREAD LOCKER
4	86883	SCREW M6X16	2	10N·m
5	86447	BOLT, TENSIONER	1	10N·m
6	86878	CAMSHAFT 240°	1	for 190F, FDX, FLX
6	87163	CAMSHAFT 150CC	1	for 150F, FDX, FLX
6	87347	CAMSHAFT COMP, 00	1	for 190F, 150F
7	86391	CHAIN, CAMSHAFT DRIVE	1	94L
8	86402	COTTER, VALVE	8	
9	87622	SHAFT W/WEIGHT, DECOMP. VER.2	1	
10	86395	GUDE , CHAIN CAMSHAFT	1	
11	86389	PLATE, STOPPER CAM	1	
12	86400	RETAINER, SPRING VALVE	4	
13	86403	SEAL, VALVE STEM Φ 4.5	4	
14	86401	SEAT, SPRING VALVE	4	
15	86392	SHAFT, ROCKER	2	
16	87621	SPRING, RETURN DECOMP. VER.2	1	
17	86624	SPRING, VALVE	4	for 190F, FDX, FLX/150F
17	87343	SPRING, VALVE	4	for 150FDX, FLX
18	86879	SPROCKET, CAMSHAFT DRIVEN	1	34T
19	87620	PLATE, STOPPER DECOMP. VER.2	1	
20	86394	TENSIONER, CAM CHAIN	1	
21	86623	VALVE, EXHAUST Φ 21	2	
22	86397	VALVE, INTAKE Φ 24.5	2	

PARTS CATALOGUE
Engine No. ANIMA 190/150 FDX/FLX: 2745000000-
Engine No. ANIMA 190/150 F : 2745000000-



03 PISTON / CRANKSHAFT

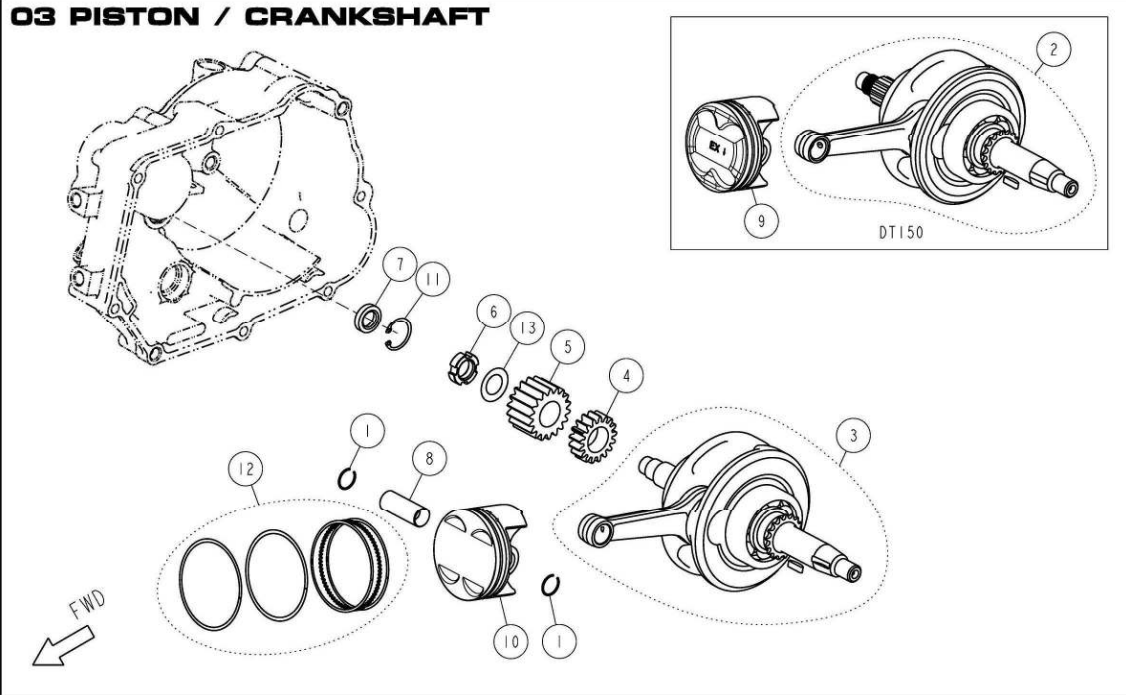

Ref No.	Part No.	DESCRIPTION	QTY	REMARKS
1	86453	CLIP, PIN PISTON	2	
2	86381	CRANK SHAFT ASSY 150F	1	STROKE 49.6mm
3	86620	CRANK SHAFT ASSY 190F	1	STROKE 62.0mm
4	86383	GEAR, OIL PUMP DRIVE	1	17T
5	86415	GEAR, PRIMARY DRIVE	1	18T
6	83768	NUT, SMALL M14	1	64N·m
7	86443	OIL SEAL, Φ 12xΦ 20x5t	1	
8	86379	PIN, PISTON Φ 14	1	
9	86378	PISTON for 150F	1	BORE Φ 62.0
10	86621	PISTON for 190F	1	BORE Φ 62.0
11	86462	RETAINING RING, RTWN22	1	
12	86380	RING SET, PISTON	1	
13	86411	WASHER, SPRING	1	

PARTS CATALOGUE
Engine No. ANIMA 190/150 FDX/FLX: 2745000000-
Engine No. ANIMA 190/150 F : 2745000000-



04 CRANKCASE

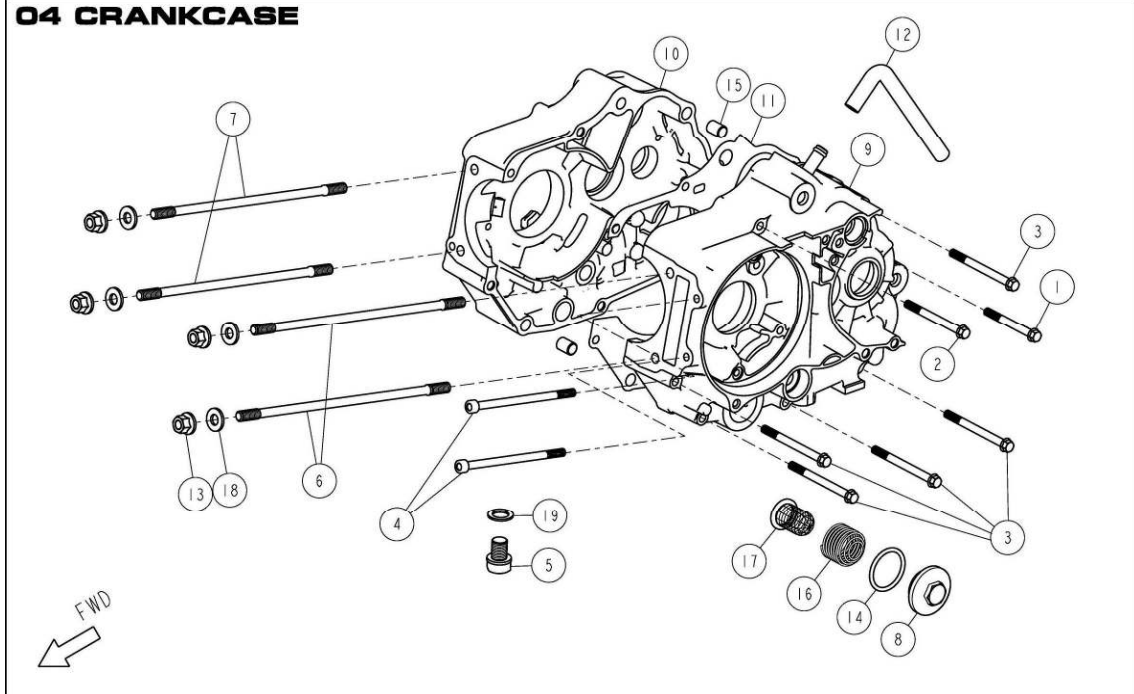

Ref No.	Part No.	DESCRIPTION	QTY	REMARKS
1	86474	BOLT, HEXAGON FLANGE M6x55	1	
2	83761	BOLT, HEXAGON FLANGE M6x65	1	
3	86360	BOLT, HEXAGON FLANGE M6x70	5	
4	86459	BOLT, HEXAGON SOCKET M6x105	2	8N·m
5	83755	BOLT, OIL DRAIN M12x1.5	1	25N·m
6	86444	BOLT, STUD A	2	M8xP1.25 L=223mm
7	86445	BOLT, STUD B	2	M8xP1.25 L=203.5mm
8	86369	COVER, STRAINER OIL	1	12N·m
9	86370	CRANK CASE, LH	1	
10	86884	CRANK CASE, RH	1	
11	86438	GASKET, CRANKCASE	1	
12	86371	HOSE, BREATHER	1	
13	86451	NUT FLANGE, M8	4	22N·m
14	86433	O-RING, Φ 30xΦ 3	1	
15	83720	PIN, DOWEL Φ 10xΦ 8.4x14	2	
16	86385	SPRING, STRAINER	1	
17	86387	STRAINER, OIL	1	
18	86457	WASHER, GASKET M8	4	
19	83754	WASHER, OIL DRAIN M12	1	

PARTS CATALOGUE
 Engine No. ANIMA 190/150 FDX/FLX: 2745000000-
 Engine No. ANIMA 190/150 F : 2745000000-

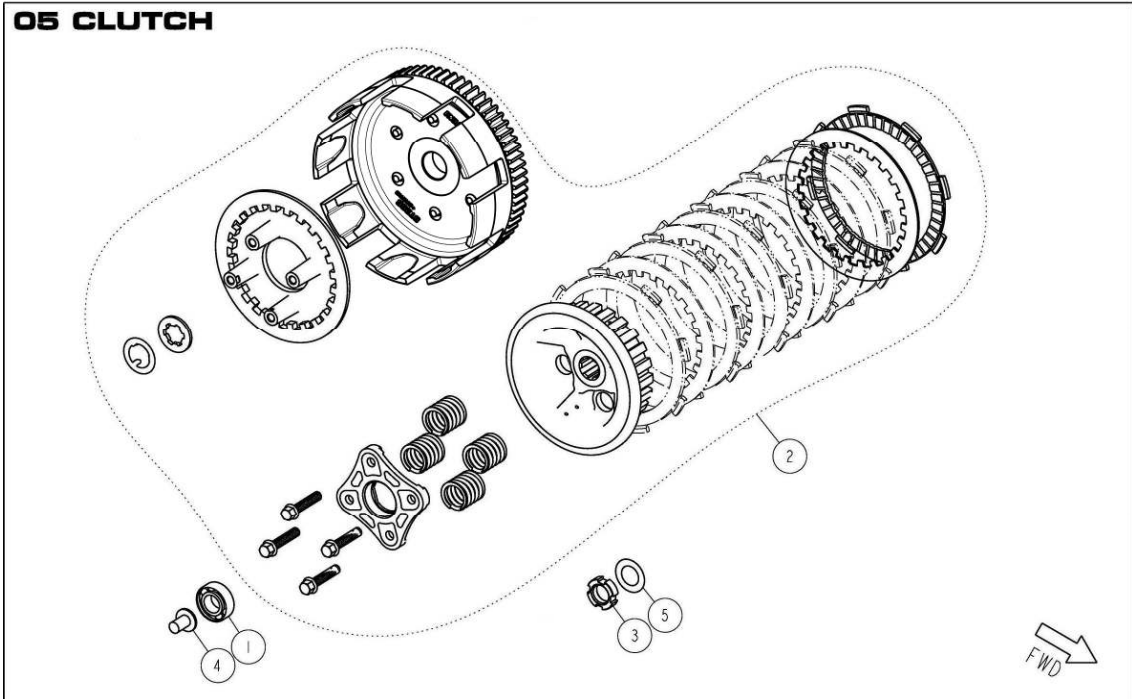

Ref No.	Part No.	DESCRIPTION	QTY	REMARKS
1	83786	BEARING, #6000	1	
2	87619	CLUTCH ASSY,W/FORGED GEAR	1	
3	83768	NUT, SMALL M14	1	64N·m
4	83787	PIN, LIFTER CLUTCH	1	
5	86410	WASHER, SPRING $\Phi 24 \times \Phi 14.2 \times 1.2$	1	

PARTS CATALOGUE
Engine No. ANIMA 190/150 FDX/FLX: 2745000000-
Engine No. ANIMA 190/150 F : 2745000000-



06 COVER CLUTCH

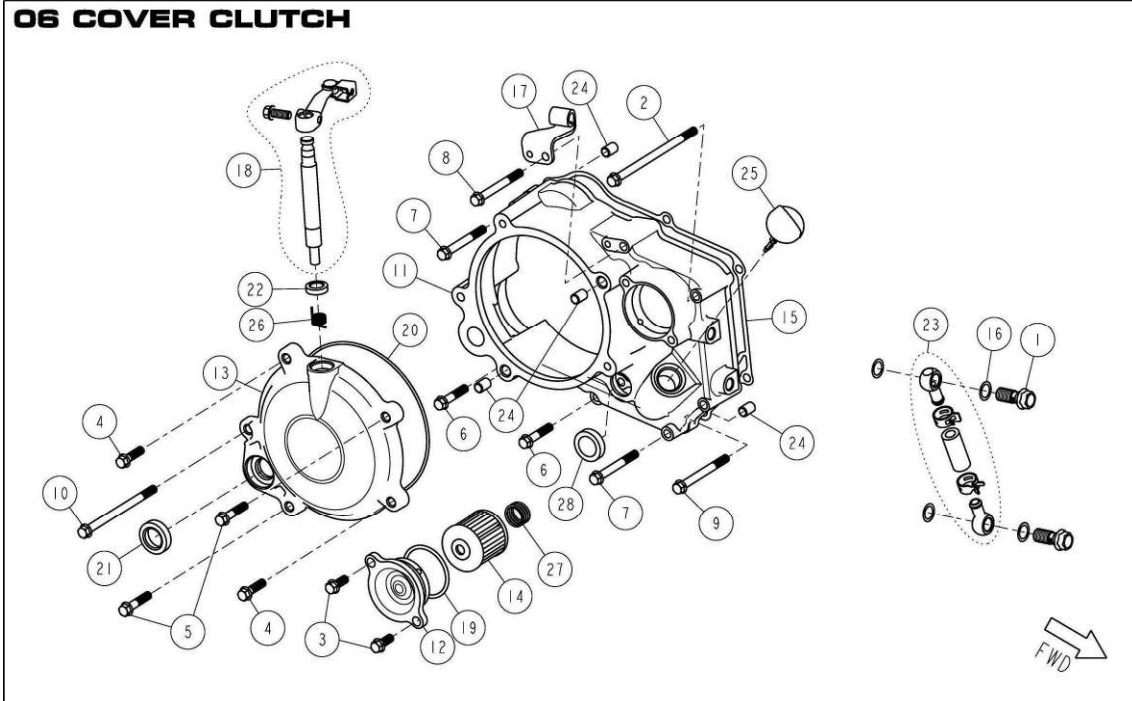

Ref No.	Part No.	DESCRIPTION	QTY	REMARKS
1	86446	BOLT, BANJO M10x22.5	2	
2	86362	BOLT, HEXAGON FLANGE M6x105	1	
3	86486	BOLT, HEXAGON FLANGE M6x15	2	
4	86469	BOLT, HEXAGON FLANGE M6x22	2	
5	86485	BOLT, HEXAGON FLANGE M6x28	2	
6	86471	BOLT, HEXAGON FLANGE M6x30	2	
7	86473	BOLT, HEXAGON FLANGE M6x50	2	
8	86474	BOLT, HEXAGON FLANGE M6x55	1	
9	83759	BOLT, HEXAGON FLANGE M6x60	1	
10	86361	BOLT, HEXAGON FLANGE M6x90	1	
11	86376	COVER, CLUTCH	1	
12	86374	COVER, OIL FILTER	1	
13	86377	COVER, SMALL CLUTCH	1	
14	83489	FILTER, OIL	1	
15	86437	GASKET, COVER CLUTCH	1	
16	86476	GASKET, M10	4	
17	86412	HOLDER, CABLE CLUTCH	1	
18	86414	LEVER, CLUTCH COMP	1	
19	86432	O-RING, $\Phi 38.6 \times 2.6$	1	
20	86435	O-RING, COVER SMALL CLUTCH	1	
21	86441	OIL SEAL, $\Phi 16 \times \Phi 26 \times 7$	1	
22	86442	OIL SEAL, $\Phi 17 \times \Phi 10 \times 5$	1	
23	86406	OIL THROUGH COMP	2	
24	83747	PIN, DOWEL $\Phi 8 \times \Phi 6.3 \times 12$	4	
25	86386	RULER	1	
26	86413	SPRING, LEVER CLUTCH	1	
27	86375	SPRING, OIL FILTER	1	
28	86475	WINDOW, OIL LEVEL	1	

PARTS CATALOGUE
Engine No. ANIMA 190/150 FDX/FLX: 2745000000-
Engine No. ANIMA 190/150 F : 2745000000-

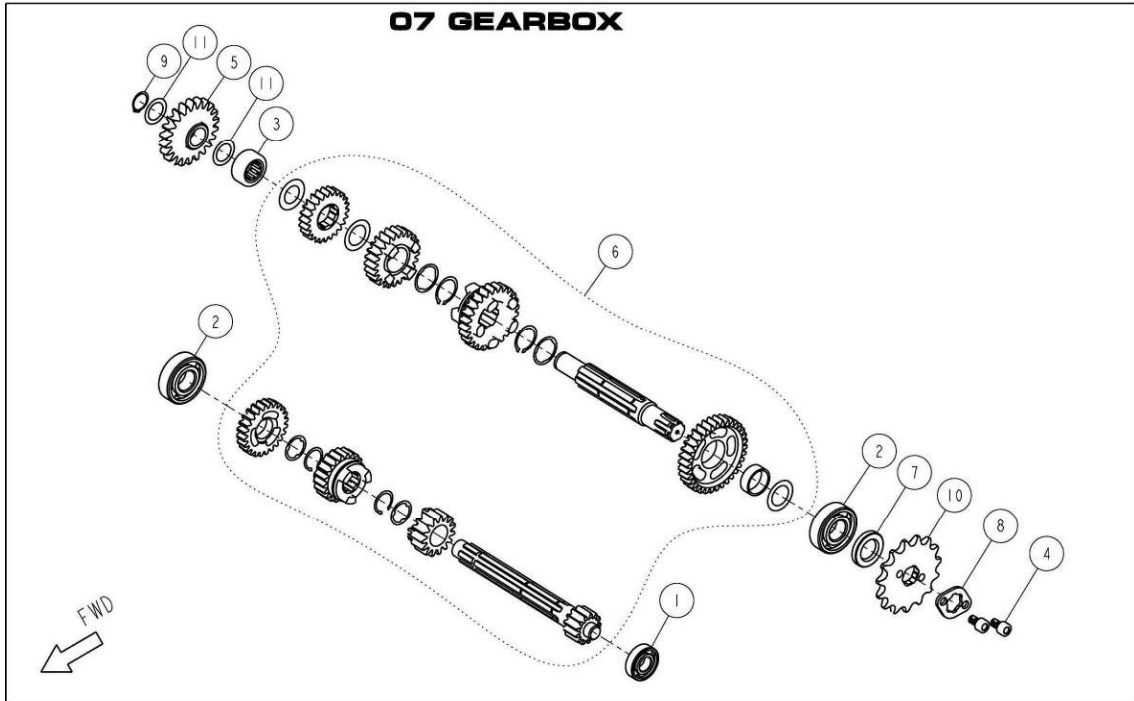

Ref No.	Part No.	DESCRIPTION	QTY	REMARKS
1	83788	BEARING #6001	1	
2	83795	BEARING #6203	2	
3	86454	BEARING NK152712	1	
4	86464	BOLT, HEXAGON SOCKET M6x10	2	
5	86418	GEAR IDLE, STARTER	1	
6	86416	GEAR, COMP, F	1	for F
6	86919	GEAR, COMP, FDX/FLX	1	for FDX, FLX
7	83796	OIL SEAL, Φ 29x Φ 17x5	1	
8	86420	PLATE, FIXING SPROCKET DRIVE	1	
9	86463	RETAINING RING Φ 13.6	1	
10	86419	SPROCKET, DRIVE 15T	1	
11	86455	WASHER, Φ 22x Φ 15x0.5	2	

***** Gear ratio of #86416 *****

GEAR,ASSEMBLY (MAIN & COUNTER)		(4speed)			
	1st	2nd	3rd	4th	
MAIN	13	15	21	24	
COUNTER	34	26	25	22	
	(2.6153)	(1.7333)	(1.1904)	(0.9166)	

***** Gear ratio of #86919 *****

GEAR,ASSEMBLY (MAIN & COUNTER)		(4speed)			
	1st	2nd	3rd	4th	
MAIN	13	15	20	23	
COUNTER	34	26	26	24	
	(2.6153)	(1.7333)	(1.3000)	(1.0435)	

PARTS CATALOGUE

Engine No. ANIMA 190/150 FDX/FLX: 2745000000-

Engine No. ANIMA 190/150 F : 2745000000-

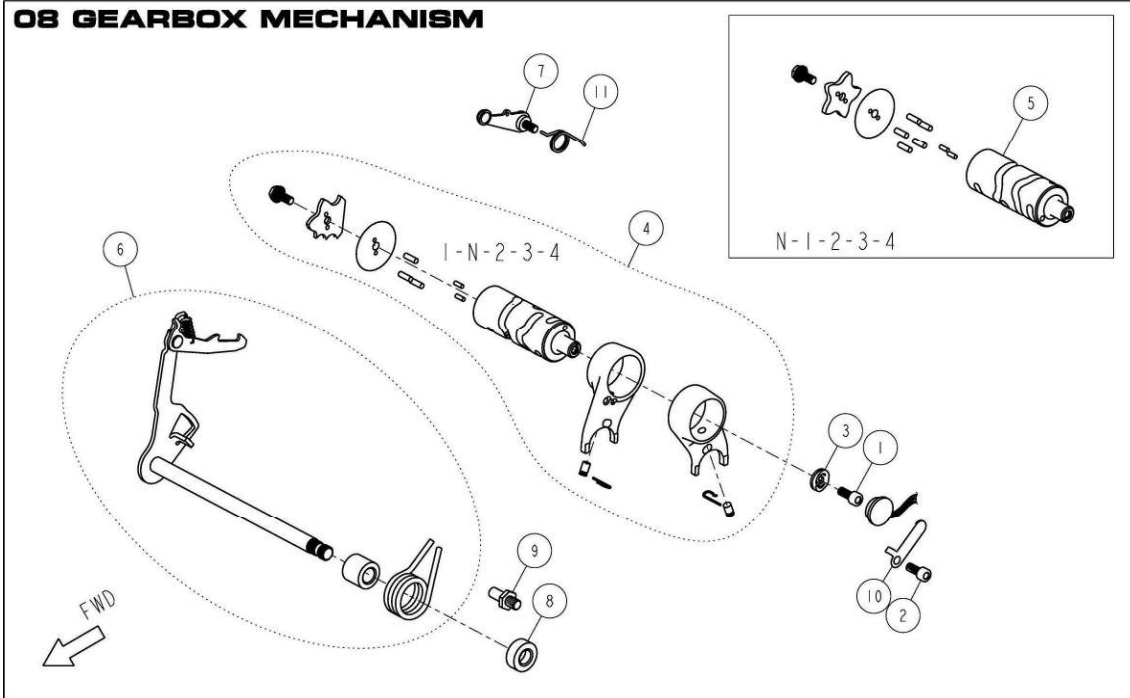

Ref No.	Part No.	DESCRIPTION	QTY	REMARKS
1	86449	BOLT, HEXAGON SOCKET M6	1	
2	85877	BOLT, HEXAGON SOCKET M6x15	1	
3	83833	CONTACT, GEAR INDICATION	1	
4	87177	DRUM, SHIFT 1-N-2-3-4 COMP	1	for F
5	86421	DRUM, SHIFT N-1-2-3-4 COMP	1	for FDX, FLX
6	87178	LEVER, GEAR SHIFT COMP	1	for F
6	86915	LEVER, GEAR SHIFT COMP	1	for FDX, FLX
7	86424	LOCATING PLATE UNIT	1	12N·m
8	83837	OIL SEAL, $\Phi 24 \times \Phi 16 \times 10$	1	
9	86480	PIN, LOCATING SHIFT LEVER	1	15N·m
10	85876	PLATE, LOCATING SWITCH N.	1	
11	86423	SPRING, LOCATING PLATE	1	

PARTS CATALOGUE
 Engine No. ANIMA 190/150 FDX/FLX: 2745000000-
 Engine No. ANIMA 190/150 F : 2745000000-



09 OIL PUMP

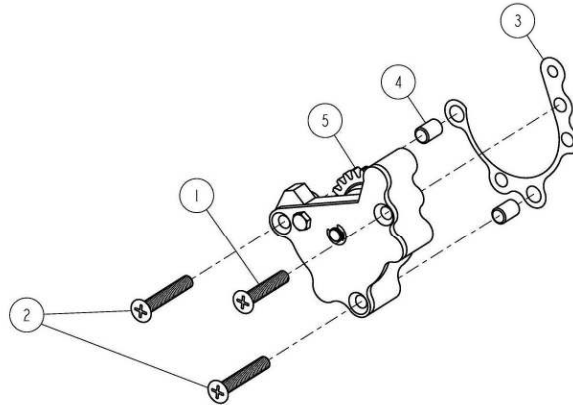

Ref No.	Part No.	DESCRIPTION	QTY	REMARKS
1	84678	BOLT, COUNTERSUNK M6x30	1	10N·m
2	84677	BOLT, COUNTERSUNK M6x35	2	10N·m
3	84676	GASKET, PUMP OIL	1	
4	83747	PIN, DOWEL $\Phi 8 \times \Phi 6.3 \times 12$	2	
5	86382	PUMP, OIL ASSY	1	

PARTS CATALOGUE
 Engine No. ANIMA 190/150 FDX/FLX: 2745000000-
 Engine No. ANIMA 190/150 F : 2745000000-



10 KICK STARTER

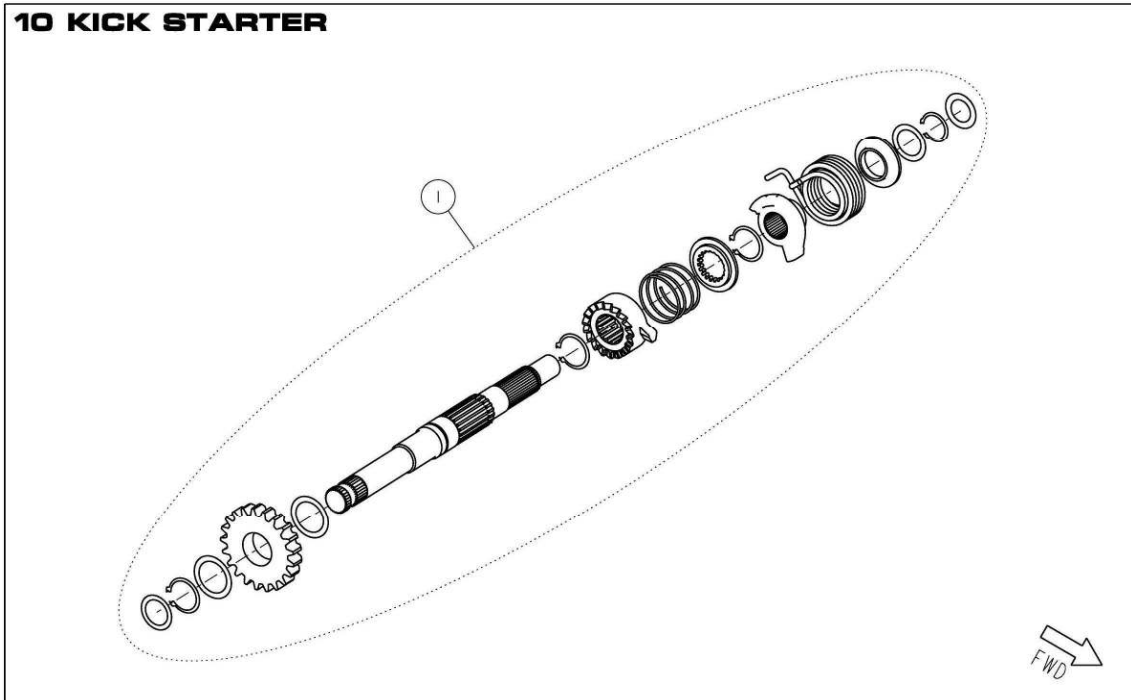

Ref No.	Part No.	DESCRIPTION	QTY	REMARKS
1	86407	KICK STARTER ASM	1	

PARTS CATALOGUE

Engine No. ANIMA 190/150 FDX/FLX: 2745000000-

Engine No. ANIMA 190/150 F : 2745000000-



11 GENERATOR

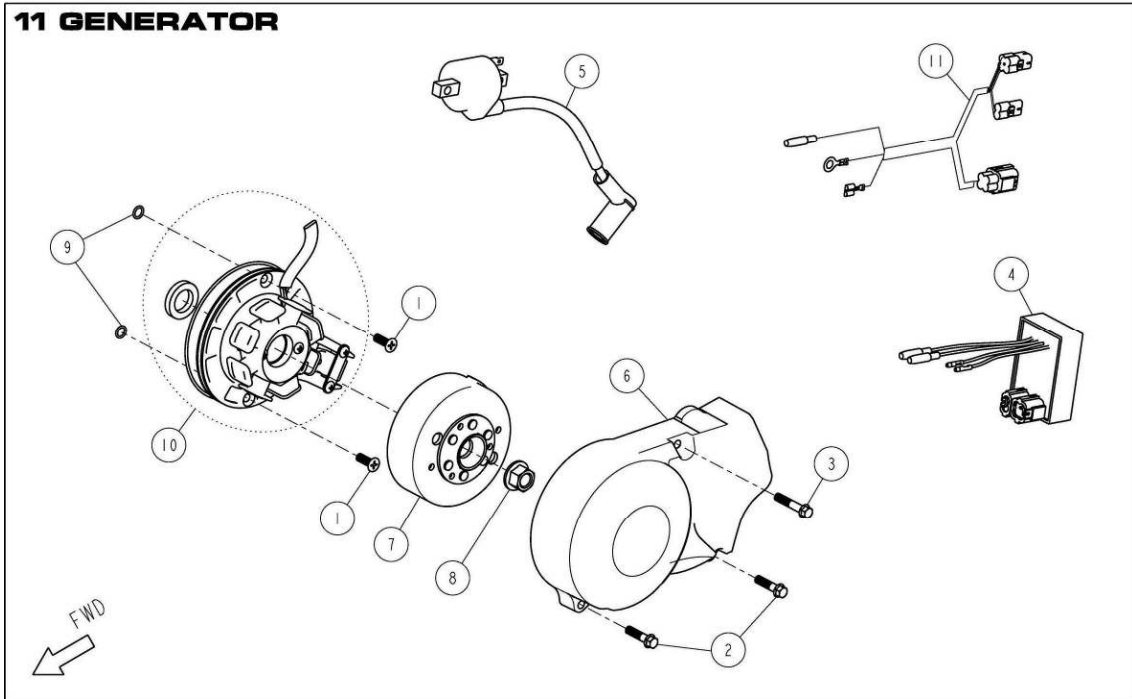

Ref No.	Part No.	DESCRIPTION	QTY	REMARKS
1	86461	BOLT, COUNTERSUNK M6x15	2	10N·m
2	86464	BOLT, HEXAGON FLANGE M6x25	2	
3	86472	BOLT, HEXAGON FLNAGE M6x32	1	
4	87348	BOX, CDI - NON SELECTABLE PROGRAM	1	for F
4	87349	BOX, CDI WITH SELECTABLE REV LIMITER	1	for FDX, FLX
5	86426	COIL, IGN ITION	1	
6	86373	COVER, MAGNET	1	
7	86431	FLYWHEE MAGNET COMP	1	
8	86452	NUT, MAGNET M12	1	64N·m
9	86479	O-RING, $\Phi 6.5 \times \Phi 1.8$	2	
10	86916	STATOR ASSY, W/O LIGHT SYSTEM	1	for FDX
10	86430	STATOR ASSY, WITH LIGHT SYSTEM	1	for F, FLX
11	86917	WIRE HERNESS, W/O LIGHT SYSTEM	1	for FDX
11	86428	WIRE HERNESS, WITH LIGHT SYSTEM	1	for F, FLX
12	87189	REGULATE RECTIFIER	1	for F, FLX

DAYTONA corp.

2016.01.01